

*SERVICE CENTRE
AUTHORISED DEALER*

OPERATING AND MAINTENANCE MANUAL

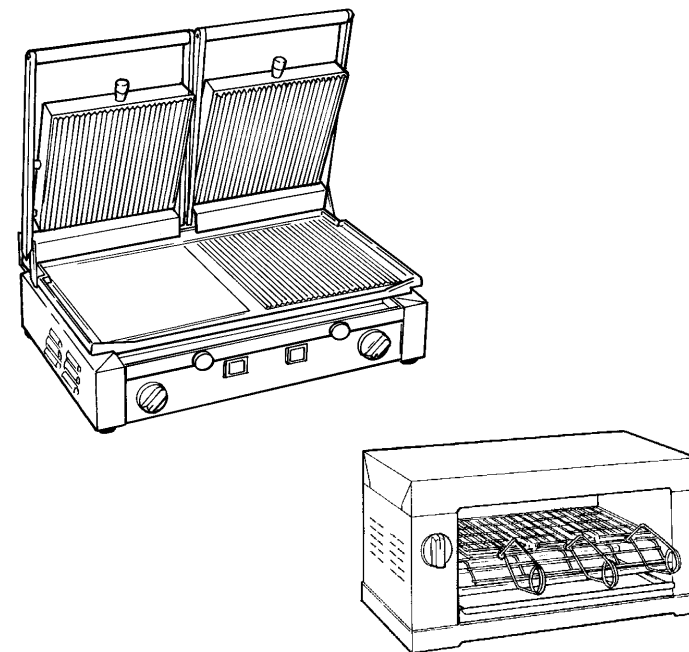

Ed. 01/2006

GRILLERS / TOASTERS

INTRODUCTION

- This manual is meant to provide **customers** with information on the machine and its specifications and the necessary operating and maintenance instructions in order to guarantee the best possible use of the machine and preserve its efficiency in the long term.
- This manual is to be used by qualified and skilled people well informed about the use of the machine and its periodical maintenance.

CONTENTS

CHAP. 1 - INFORMATION ON THE MACHINE	pag. 4
1.1 - GENERAL PRECAUTIONS	
1.2 - SAFETY DEVICES INSTALLED ON THE MACHINE	
1.2.1 - standard version	
1.2.2 - USA version	
1.3 - DESCRIPTION OF THE MACHINE	
1.3.1 - general description	
1.3.2 - manufacturing features	
1.3.3 - machine components	
CHAP. 2 - TECHNICAL DATA	pag. 6
2.1 - OVERALL DIMENSIONS, WEIGHT, CHARACTERISTICS...	
CHAP. 3 - THE ARRIVAL OF THE MACHINE	pag. 8
3.1 - DESPATCH OF THE MACHINE	
3.2 - PACKAGE CHECK UPON RECEIPT	
3.3 - PACKAGE DISPOSAL	
CHAP. 4 - INSTALLATION	pag. 9
4.1 - SETTING UP OF THE MACHINE	
4.2 - ELECTRICAL CONNECTIONS	
4.3 - ELECTRIC CIRCUIT DIAGRAM OF THE GRILLERS	
4.3.1 - electric circuit diagram of the GRILLERS: DOPPIA M/R/L/X	
4.3.2 - schema elettrico delle PIASTRE: DOPPIA-C M/R/L/X	
4.3.3 - electric circuit diagram of the GRILLERS: DOPPIA-TOP M/R/L/X	
4.3.4 - electric circuit diagram of the GRILLERS: MEDIA R/L/X; MEDIA-CRÊPÊS; SINGOLA R/L	
4.4 - ELECTRIC CIRCUIT DIAGRAM of the TOASTERS	
4.4.1 - electric circuit diagram of the TOASTERS: 4 TQ, 6 TQ and 6 TC	
4.4.2 - electric circuit diagram of TOASTERS: 12 TQ and 12 TC	
4.5 - FUNCTIONING CHECK	

CHAP. 8 - DISPOSAL OF THE MACHINE

8.1 - PUTTING THE MACHINE OUT OF SERVICE

If for some reason, you decide to put the machine out of service, make sure nobody can use it: **disconnect it from the mains and eliminate the electrical connections.**

8.2 - DISPOSAL

When the machine is out of service, it can be eliminated. To dismantle the machine contact a Specialized Centre, paying attention to the different materials used (see chap. 1 par. 3.2).

CHAP. 6 - GENERAL CLEANING

6.1 - INTRODUCTION

- the machine cleaning is an operation that has to be performed at least once a day and, if necessary more often.
- All the machine parts, that are in contact with the product, must be cleaned accurately .
- Never clean the machine by means of compressed water or water jets.
- The cleaning of the TOASTERS must be performed when the machine is cold, clean the quartz lamps with a cotton flock soaked in alcohol.
- The cleaning of the GRILLER can be performed when it is hot, scrape with a metallic brush on the cooking grid several times, pay the maximum **ATTENTION** not to touch the cooking surface because this could cause dangerous burns.
- Take the same care **when emptying the collecting tray for gravy.**
- It is advisable to perform these cleaning operations when the GRILLER temperature is at the minimum so that the residual grease which sticks to the grid can melt.
- It is absolutely forbidden to pour water or other liquids on the grid when it is hot, because the changes of temperature can provoke their breaking.
- **WARNING:** Before performing any cleaning operation, **disconnect the machine plug from the mains to insulate it from the rest of the installation.**

CHAP. 7 - MAINTENANCE

7.1 - GENERAL FEATURES

Before performing any maintenance operations, it is necessary to **disconnect the plug from the socket to insulate completely the machine from the rest of the system.**

7.2 - POWER SUPPLY CORD

Periodically check whether the power supply cord is worn-out and, if this is the case, please call the “SERVICE CENTRE” to have it replaced.

7.3 - QUARZ TUBES (TOASTERS)

Periodically check whether the quartz tubes of the TOASTERS are worn-out, because the place of the pliers on the grid and or the moving of the machine from one place to another, could provoke the breakage of the tubes. In this case, please call the “SERVICE CENTRE” to have them replaced.

CHAP. 5 - USE OF THE MACHINE

5.1 - CONTROLS

5.2 - FIRST USE OF THE MACHINE

CHAP. 6 - GENERAL CLEANING

6.1 - INTRODUCTION

CHAP. 7 - MAINTENANCE

7.1 - GENERAL FEATURES

7.2 - POWER SUPPLY CORD

7.3 - QUARTZ TUBES (TOASTER)

CHAP. 8 - DISPOSAL OF THE MACHINE

8.1 - PUTTING THE MACHINE OUT OF SERVICE

8.2 - DISPOSAL OF THE MACHINE

pag. 16

pag. 18

pag. 18

pag. 19

CHAP. 1 - INFORMATION ON THE MACHINE

1.1 - GENERAL PRECAUTIONS

- The machine must be operated only by highly qualified people who are fully aware of the safety measures described in this manual.
- In case of a personnel turn over, training is to be provided in advance.
- Before starting cleaning and maintenance operations, disconnect the plug from the supply socket.
- Assess the residual risks carefully to carry out cleaning and maintenance.
- Cleaning and maintenance require great concentration.
- A regular control of the electric supply cord is absolutely necessary; a worn-out or damage cord is very dangerous.
- If the machine shows malfunctions, it is recommended not to use it and to abstain from trying to repair it; please call the "Service Centre".
- The GRILLERS and TOASTERS are used for cooking, heating, toasting, and to grill foodstuffs. Do not use the machine for other uses or for any products other than foodstuffs.
- The manufacturer is not liable in the following cases:
 - ⇒ if the machine has been tampered by non-authorized personnel;
 - ⇒ if some parts have been substituted by non original spare parts;
 - ⇒ if the instructions contained in this manual are not followed **accurately**;
 - ⇒ if the machine surface is not cleaned with the right product.

1.2 - SAFETY DEVICES INSTALLED ON THE MACHINE

1.2.1 - standard version

The electrical safety devices installed on the machine, described in this manual, complies with **EC 73/23, 89/336, mod. EC 91/368, 92/31, 93/44, 93/68** and regulations **EC EN 60335-1, EN 55014**.

Even though the GRILLERS and TOASTERS are provided with electrical and mechanical protections (when the machine is working and for maintenance and cleaning operations), there are still **RESIDUAL RISKS** that cannot be eliminated completely, these risks are mentioned in this manual under **WARNING**. These risks are scalds caused by the loading and unloading of the product, or other kind of injuries due to the maintenance operations.

for 15-20 minutes.

WARNING: When you place the product on the grid to cook it, this must be hot, so pay attention to residual risks due to burning dangers.

To load the product follow this procedure:

1. place yourself in a correct position (*FIG. n°13*), avoiding any contact with the machine;
2. choose the correct temperature using the knob (for the grillers) and regulate the heating intensity for the toasters;
3. when the griller or the toaster is hot, place the product and start the cooking;
4. at the end of the cooking, remove the residuals from the grid;
5. if the griller is inactive for a long period (f.i. one or two hours), place the knob to 0 °C.

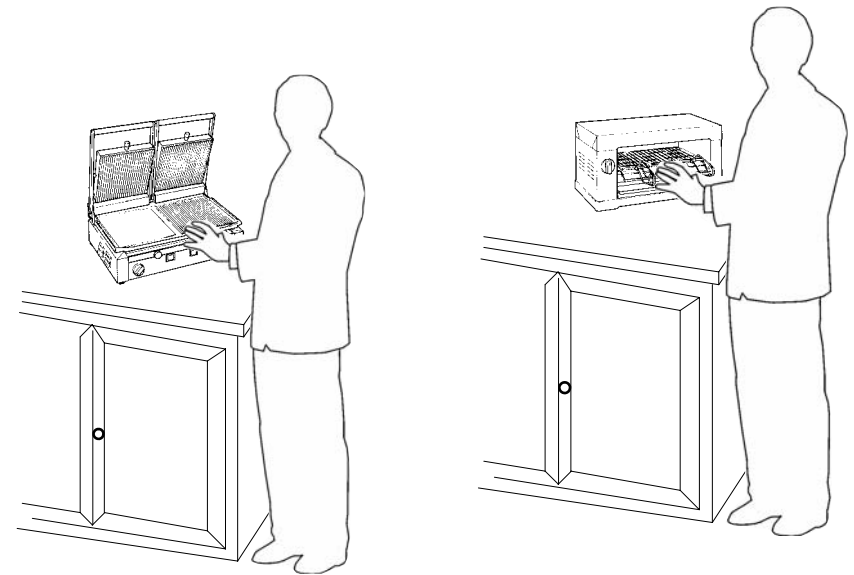

FIG. n°13 - Correct position for cooking

"If the machine has been turned off longer than 30 min., allow at least 10 min. for it to reach cooking temperature again. If you are not using the machine, but you think you are going to need it soon, set the temperature at 120 F, this will allow the machine to reach cooking temperature faster".

4.5 - FUNCTIONING CHECK

To check the machine functioning, just turn the “start” regulator knob **clockwise** (placing yourself in front of the knob), and starting from the minimum, observe if the pilot lamp turns on .

When the pilot lamp is on, it means that **the machine is functioning.**

CHAP. 5 - USE OF THE MACHINE

5.1 - CONTROLS ON THE GRILLERS

The controls are placed on the machine has shown in the figure below.

- 1 Thermostat
- 2 Pilot lamp, it indicates that the resistors are on.

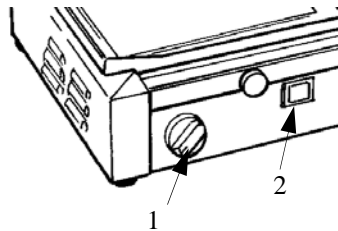

FIG. n°11 - Controls position on the grillers

5.2 - CONTROLS ON THE TOASTERS

The controls are placed on the machine as shown in the figure below.

- 1 Timer, for cooking time regulation.

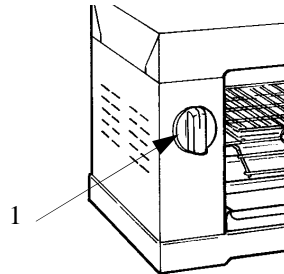

FIG. n°12 - Controls position on the toasters

5.3 - FIRST USE OF THE MACHINE

When the machine is delivered, the steel surfaces are protected with a nylon anti-scratch film. This film has to be removed accurately before starting the machine and pay attention to remove eventual residuals of glue.

To perform this operation, do not use sharpening tools, inflammable or abrasive substances.

The insulating materials used during the manufacturing and the residuals of grease due to the mechanical installation of single parts, heat and produce smoke, for this reason, **it is necessary to start the machine outside, putting it at the maximum**

1.2.2 - USA version

Complies with:

- UL 197, 8° edition
- NSF 4, 1991 edition

1.3 - DESCRIPTION OF THE MACHINE

1.3.1 - General description

Our firm has designed and manufactured the GRILLERS and TOASTERS to cook, heat, toast, grill foostuffs (as fish, meat, vegetables, etc.) and to guarantee:

- the highest degree of safety in functioning, cleaning and maintenance;
- the highest hygienic standard due to an accurate choice of materials which come into contact with the foodstuffs;
- the lowest loss of heat produced by the resistances;
- solidity and stability of all the elements;
- great handiness.

1.3.2 - Manufacturing features

The TOASTERS are completely made of stainless steel AISI 430. This material guarantees the contact with the food (hygienic) and high resistance to acids, salts and oxidation processes.

The structure of the GRILLERS DOPPIA R-M-L; MEDIA R-L; SINGOLA R-L is made of stainless steel AISI 430 and the cooking gridirion is made of a special cast iron treated with vetrified food enamel, this guarantees hygienic conditions and high resistance to acids, salts and oxydation processes. The structure of the DOPPIA X and the MEDIA X is made of stainless steel AISI 430 and the cooking grid is made of stainless steel AISI 304.

1.3.3 - Machine components

FIG. n°1 - General view of the machine

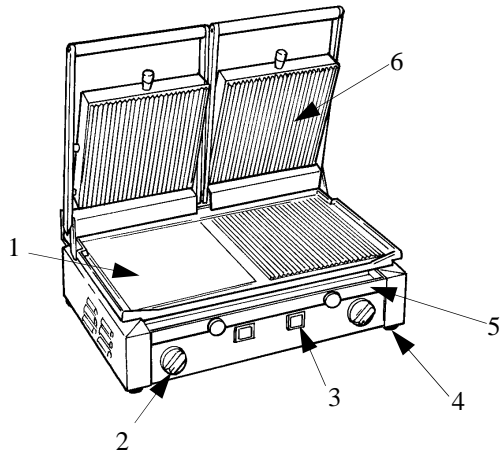

LEGEND:

GRILLERS

- | | |
|---|---------------------------|
| 1 | Lower cooking grid |
| 2 | Thermostat |
| 3 | Functioning pilot lamp |
| 4 | Feet |
| 5 | Collecting tray for gravy |
| 6 | Upper cooking grid |

4.4 - ELECTRICAL CIRCUIT DIAGRAM OF THE TOASTERS

4.4.1 - electrical circuit diagram of the 4 TQ, 6 TQ and 6 TC

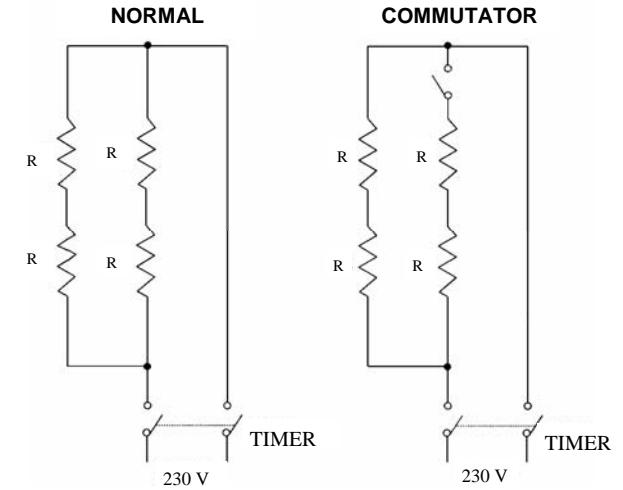

FIG. n°9 - electrical circuit diagram of the TOASTERS: 4 TQ; 6 TQ and 6 TC

4.4.2 - electrical circuit diagram of the TOASTERS: 12 TQ and 12 TC

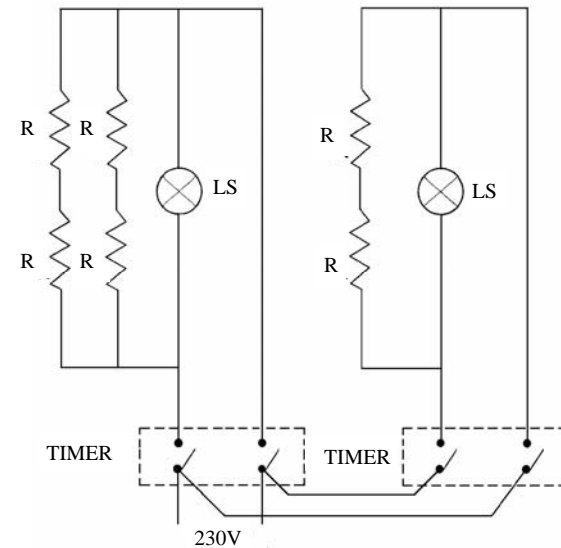
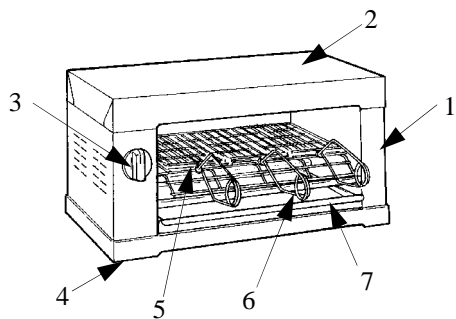

FIG. n°10 - Electrical circuit diagram of the TOASTERS: 12 TQ and 12 TC



LEGEND:

TOASTERS

- | | |
|---|-----------------------|
| 1 | Frame |
| 2 | Upper cover |
| 3 | Timer |
| 4 | Feet |
| 5 | Grid |
| 6 | Pliers |
| 7 | Crumb collecting tray |

**4.3.4 - electrical circuit diagram of the GRILLERS: MEDIA R/L/X;
MEDIA-CRÊPÊS; SINGOLA R/L**

R1 - R2 = RESISTORS
LS = PILOT LAMP
T1 = THERMOSTATS

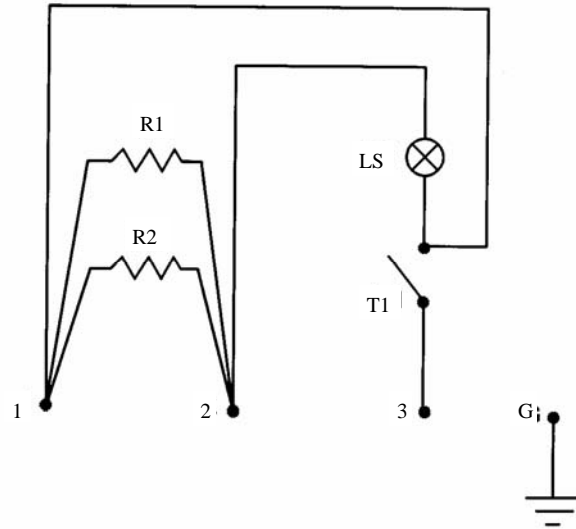

CONNECTION 115 V MN / 220 ÷ 240 V MN

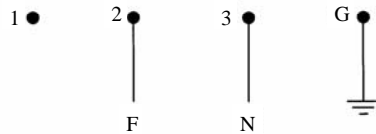
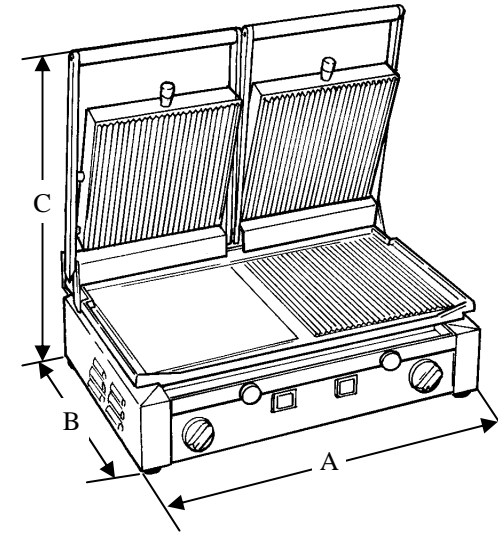

FIG. n°8 - electrical circuit diagram of the GRILLERS: MEDIA R/L/X;
MEDIA-CRÊPÊS; SINGOLA R/L

CHAP. 2 - TECHNICAL DATA

2.1 - OVERALL DIMENSIONS, WEIGHT, CHARACTERISTICS...

FIG. n°2a - Overall dimensions drawing - Grillers



Models	U.m.	SINGOLA	MEDIA MEDIA-CRÊPES	DOPPIA DOPPIA-C	DOPPIA-TOP
Lenght A	mm	260	380	515	515
Width B	mm	435	435	435	435
Height C	mm	500	500	500	170
Cooking space dimension	mm	250x255	355x255	500x255	500x255
Supply		230V / 50-60Hz 115V / 50-60Hz		230V / 50-60Hz 230-400V / TF+N 50-60Hz	
Power	W W	1550 USA 1700	2050 USA 1700	3100 USA 3000	1700 USA 1600
Plug		Shuko	Shuko	IEC 309 - 16A E+N+T	IEC 309 - 16A E+N+T
USA plug		Nema 5 - 20A	Nema 5 - 20A	Nema 6 - 20A	Nema 6 - 20A
Net weight	Kg	15	21	31	18

TAB. n°1 - Overall dimensions and technical features of the GRILLERS.

FIG. n°2b - Overall dimensions drawing -Toasters

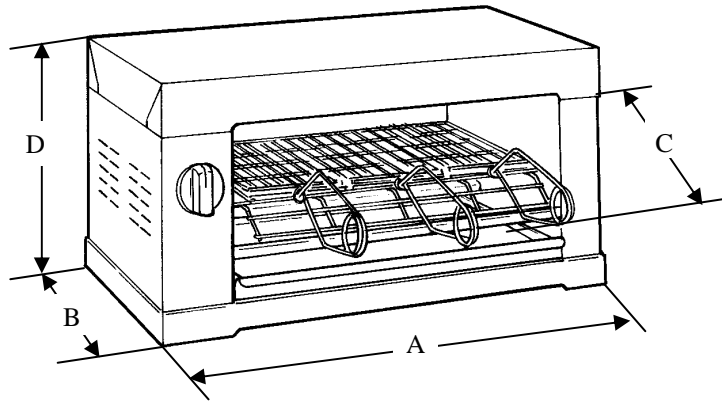

Models	U.m.	4 TQ	6 TQ	6 TC	12 TQ	12 TC
Lenght A	mm	360	475	475	475	475
Width B	mm	265	265	265	265	265
Width C	mm	410	410	410	410	410
Height D	mm	240	240	240	365	365
Number of toasts	n°	4	6	6	12	12
Supply		230V/50Hz				
Power	W W	1600	2400 2800	2900	3000 3600	4350
Net weight	Kg	6,5	7	7	8	8

TAB. n°2 - Overall dimensions and technical features of the TOASTERS.

WARNING: The electrical characteristics for which the appliance is designed are indicated on the reference plate applied on the side of the machine; before connecting to power supply, please read paragraph 4.2.

4.3.3 - electrical circuit diagram of the GRILLERS: DOPPIA-TOP L/M/R/X

R1 - R2 = RESISTORS
 LS = PILOT LAMP
 T1 - T2 = THERMOSTATS

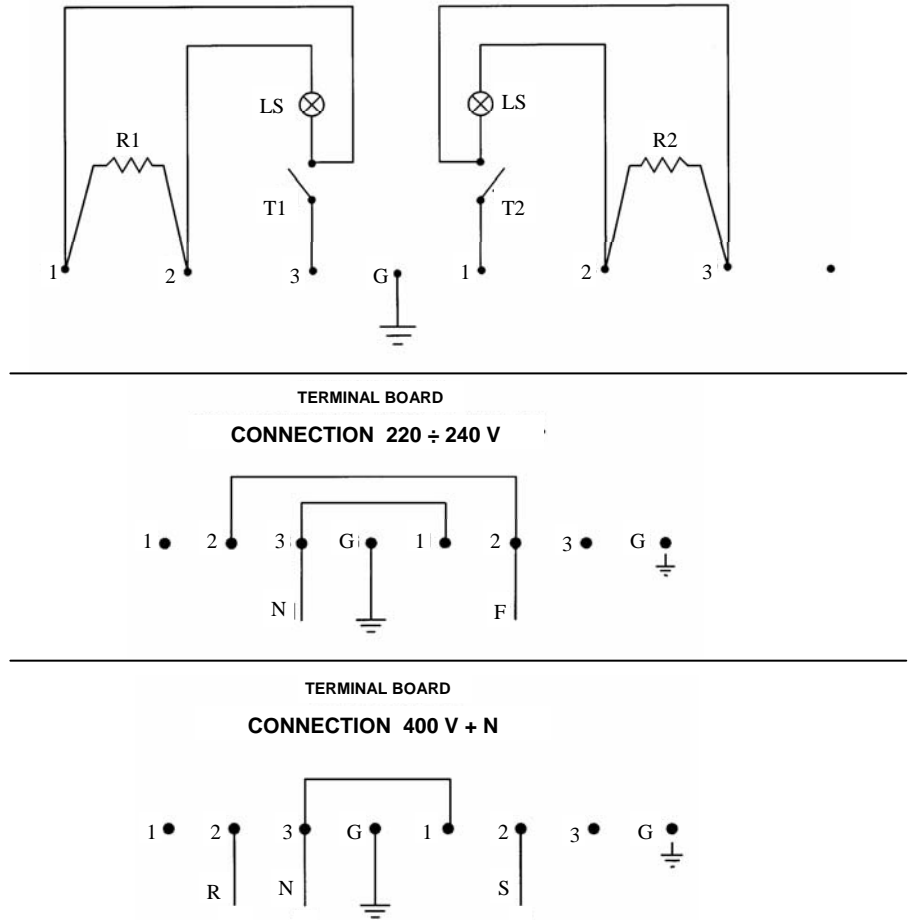

FIG. n°7 - electrical circuit diagram of the GRILLERS: DOPPIA-TOP L/M/R/X

4.3.2 - electrical circuit diagram of the GRILLERS: DOPPIA-C R/L

R1 - R2 - R3 - R4 = RESISTORS
LS = PILOT LAMP
T1 - T2 = THERMOSTATS
M1 - 3 = TERMINALS

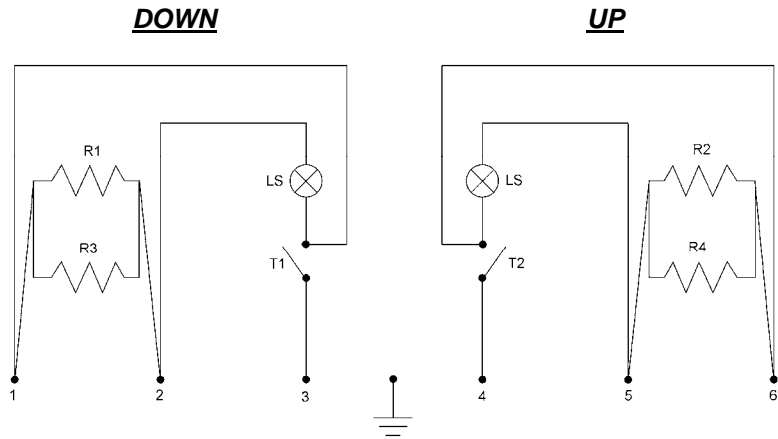

FIG. n°6 - electrical circuit diagram of the GRILLERS: DOPPIA-C R/L

CHAP. 3 - THE ARRIVAL OF THE MACHINE

3.1 - DESPATCH OF THE MACHINE (see FIG. n°3)

The GRILLERS and the TOASTERS are accurately packed and then despatched from our warehouse.

The package of the **grillers** includes:

- a) a strong cardbox + inside protections;
- b) the machine;
- c) this manual;
- d) scraper or brush (f) in accordance with the model;
- e) EC conformity declaration.

The package of the **toasters** includes:

- a) a strong cardbox + inside protections;
- b) the machine;
- c) this manual;
- e) EC conformity declaration;
- g) the pliers;
- h) the protective grids.

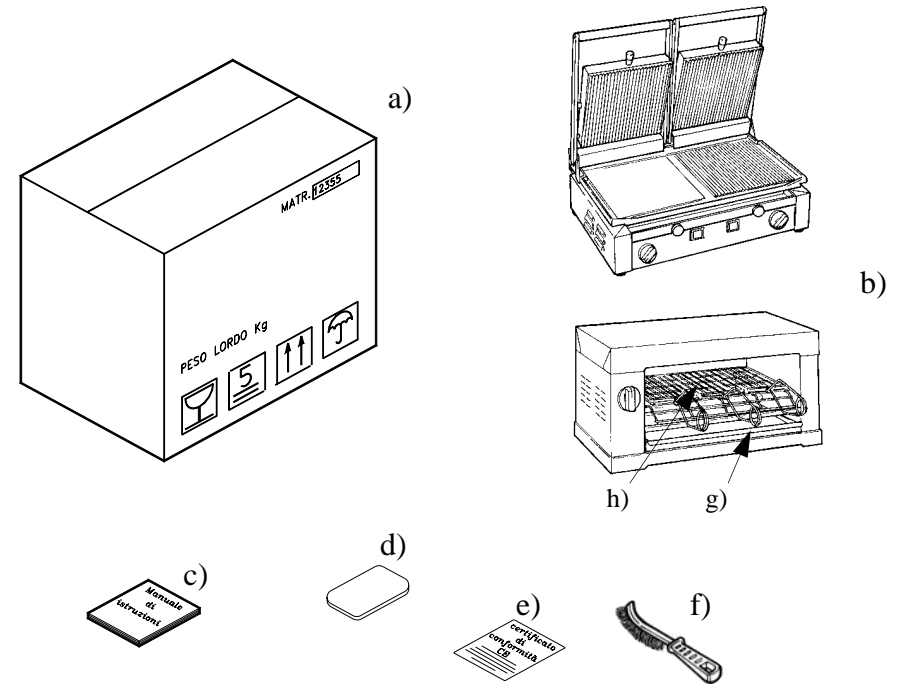

FIG. n°3 - Package description

3.2 - PACKAGE CHECK UPON RECEIPT

If no external damage is evident on the package upon its arrival, open it and check that all the components are inside (see FIG. n°3). If the package has suffered rough handling, bumps or crashes, the carrier must be informed about any damage; moreover a detailed report on the extent of the damage caused to the machine must be filled within three days from the delivery date shown in the shipping documents. **Do not overturn the package!!** When the package is transported, make sure the box is lifted by the 4 corners (parallel to the ground).

3.3 - PACKAGING DISPOSAL

The components of the packaging (cardboard, eventual pallets, plastic straps and polyurethane) are urban solid waste; therefore they can be easily disposed. If the machine has to be installed in countries where specific regulations are in force, packaging must be disposed in compliance with them.

CHAP. 4 - INSTALLATION

4.1 - SETTING UP OF THE MACHINE

The machine must be installed on a working table suitable for its overall dimensions shown in Tab. 1-2, therefore it must be adequately large, well levelled, dry, smooth, resistant, stable and placed at a height of 80 cm from the ground. Moreover the machine must be installed in a room with max. 75% not saline humidity at a temperature between +5°C and +35°C; that is to say in a place that does not provoke the machine failure.

4.2 - ELECTRICAL CONNECTIONS

The machine is equipped with a power supply cord which section is adequate to the absorb power and a plug.

To connect the machine, follow the indication of the rating plate - serial number (see FIG. n°4).

Check that the earthing is fully operational.

Moreover check that the features on the rating plate - serial number (see FIG. n°4) correspond to the features shown in the consignment and delivery note, and that the disconnecting plug and the socket are easy to reach when the machine is functioning.

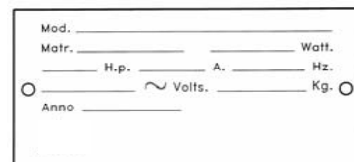

FIG.n°4 - Rating plate-serial number

4.3 - ELECTRICAL CIRCUIT DIAGRAM OF THE GRILLERS

4.3.1 - schema elettrico delle PIASTRE: DOPPIA M/R/L/X

R1 - R2 - R3 - R4 = RESISTORS
 LS = PILOT LAMP
 T1 - T2 = THERMOSTATS
 M1 - 3 = TERMINALS

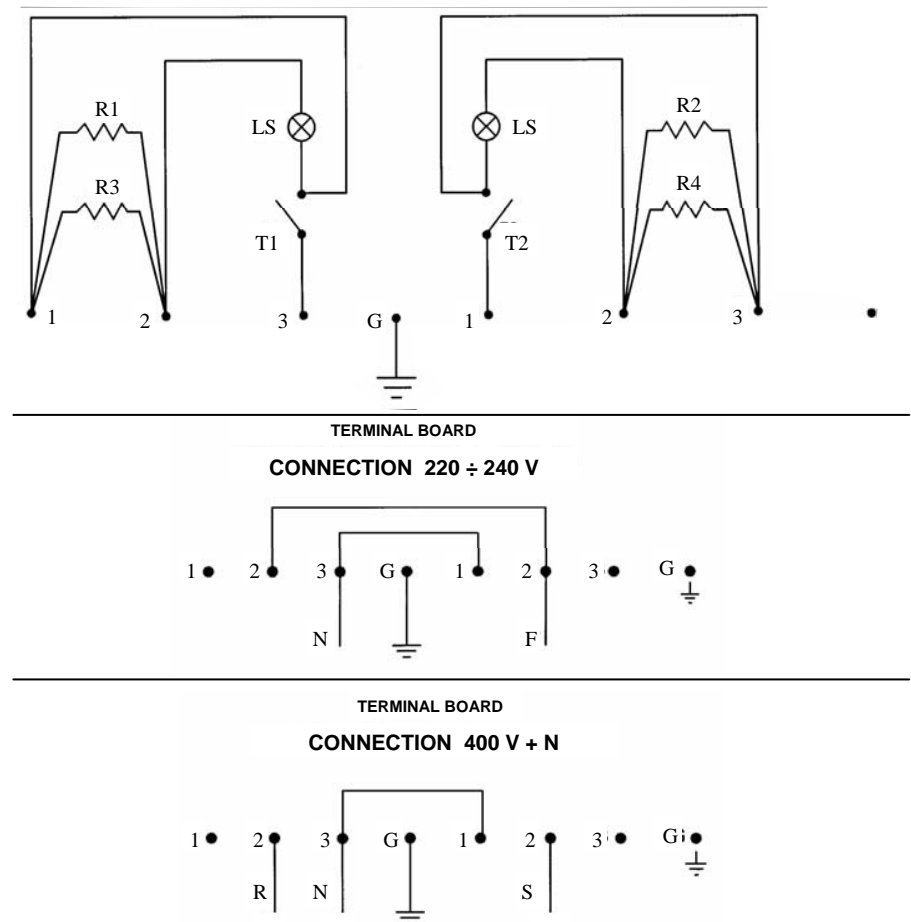

FIG. n°5 - electrical circuit diagram of the GRILLERS: DOPPIA M/R/L/X